

BRISTAN

Installation Instructions & User Guide

Please leave these instructions with the end user

Product Code: AS2 THBSM C (D5)

Specifications

Inlet Water Temperature

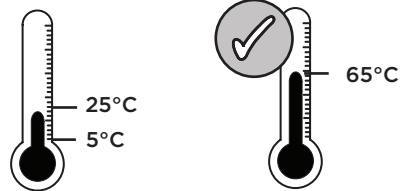

Min: 5°C Max: 25°C 65°C Maximum

Dynamic Water Pressure

Min: 0.5 bar Max: 5.0 bar

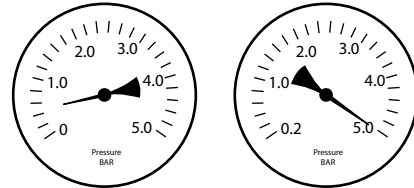

Maximum Static Pressure: 10.0 bar

Inlet Dimensions

180mm Centres

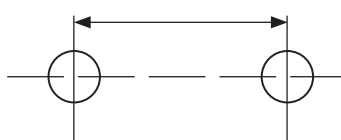

Inlet Connections

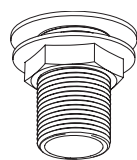

3/4" BSP

TMV Type 2 Designation

HP-T, HP-S



IMPORTANT

Please review the TMV Manual supplied with this product for testing and commissioning guidance.

Tools You'll Need

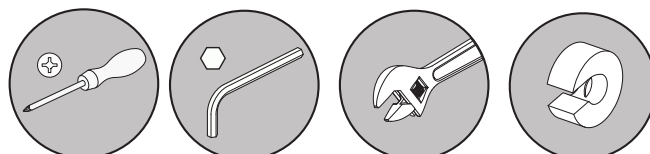

Flat Head Screwdriver Hexagonal Keys Adjustable Spanner Pipe Cutter

Prior to Installation

All products manufactured and supplied by Bristan are safe provided they are installed, used correctly and receive regular maintenance in accordance with these instructions.

This product needs to be installed in accordance with, and meet the requirements of the Water Supply (Water Fittings) Regulations 1999 and current by-laws. For full Installation Requirements & Notes (IRN) please visit wras.co.uk/directory.

A TMV Type 2 Manual has also been supplied with this product. Please refer to this manual for testing and commissioning guidance in order to ensure this product still complies to TMV Type 2 standards.

BS 6700 recommends the temperature of stored water should never exceed 65°C. A stored water temperature of 60°C is considered sufficient to meet all normal requirements and will minimise the build up of lime scale in hard water areas.

We recommend isolation valves to be fitted to the inlet water supplies to ensure ease of future maintenance. Before installing these taps the water supply must be thoroughly flushed in order to remove any swarf, solder etc. This product must not be modified in any way as this will invalidate the guarantee.

If in doubt, contact a registered plumber or your Local Water Authority or the Secretary of The Institute of Plumbing, address as follows:-

The Institute of Plumbing,
64 Station Lane,
Hornchurch,
Essex, RM12 6NB

Tel:01708 472791

Pack Contents

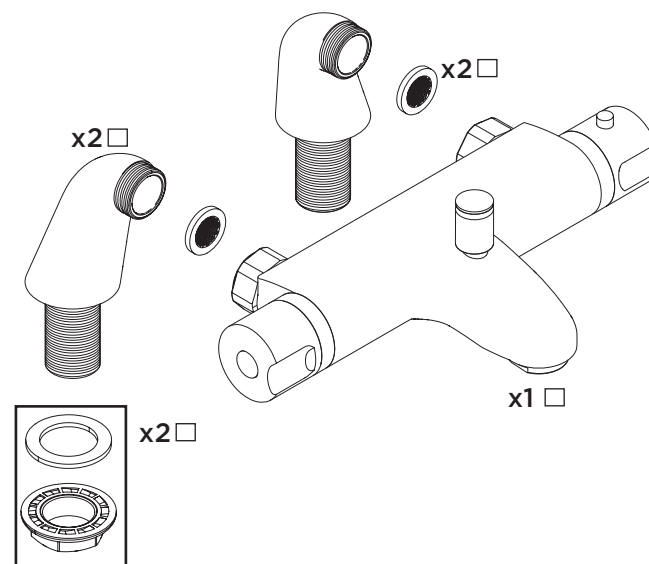

Spare Parts

To replace any spare parts for your tap, why not scan the QR Code or visit www.bristan.com and search for your product.



Installation

1

Choose whether your tap will be deck or wall mounted.

Follow the WMNT10 C instructions to install if wall mounted.

Refer to leg packaging stickers to distinguish hot and cold legs

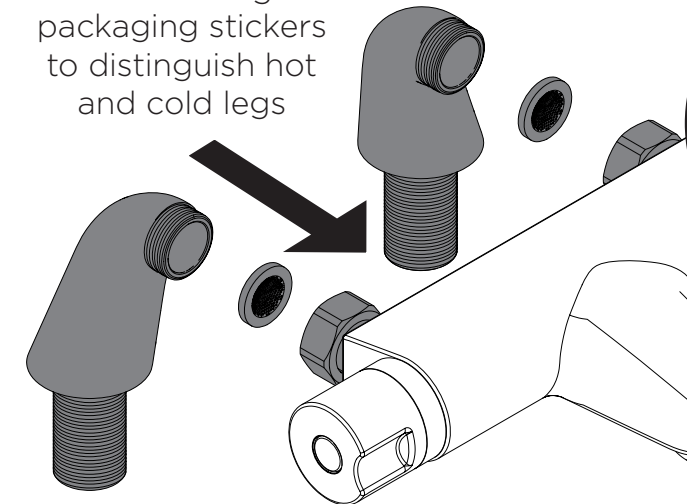

This tap can also be wall mounted using WMNT10 C. Visit www.bristan.com for more details.

If deck mounted, connect the legs supplied to the tap body, ensuring the filter washers are in place.

2

Hot on the left and Cold on the right when viewed from the front

Feed the tap legs through the bath holes, ensuring the washers are in place.

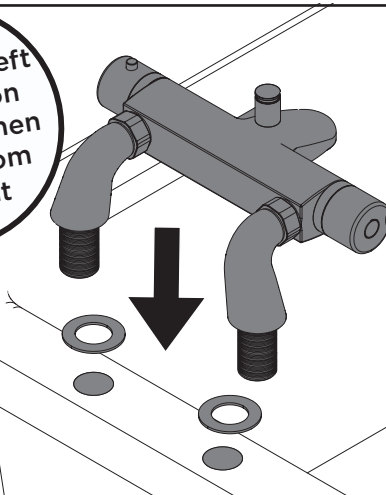

3

Secure the taps to the bath by using the washer and metal backnuts below the bath.

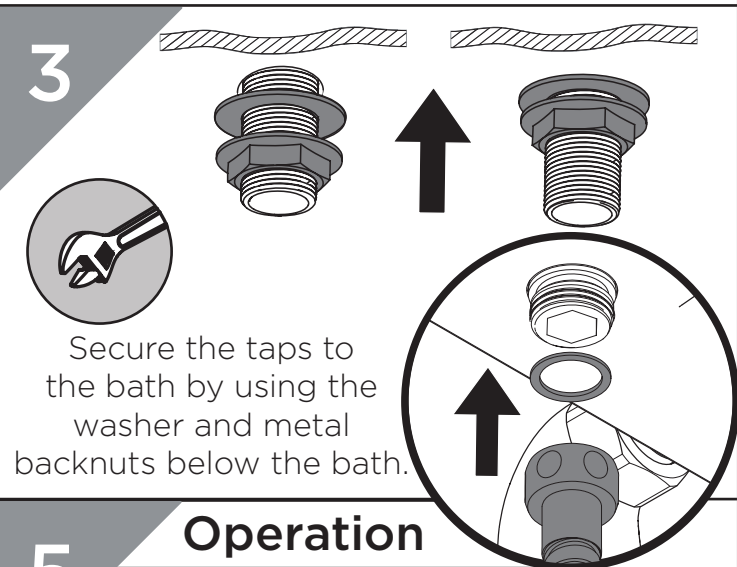

4

REMEMBER Hot on the left, cold on the right!

Hot

Cold

Connect the hot and cold water supplies to the threaded tails, ensuring the washers are in place.

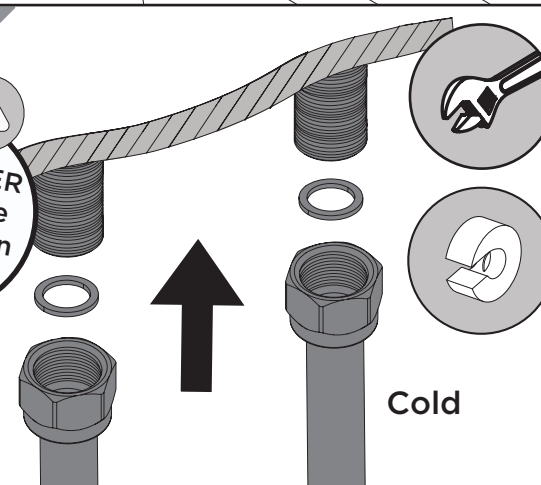

5

Operation

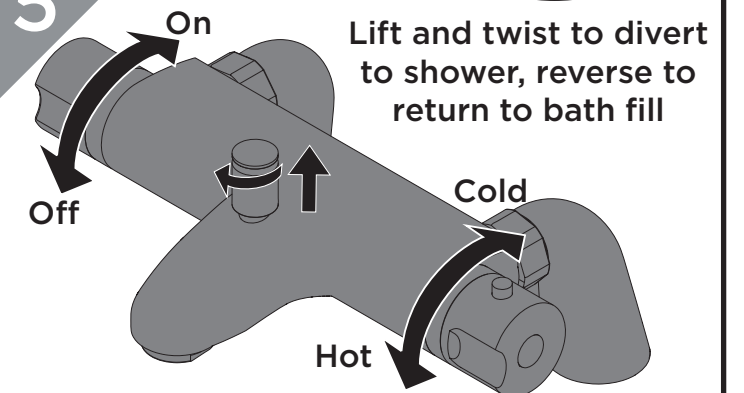

Add your choice of shower kit. Turn on water supply and check all joints and connections for leaks. **Your tap is now ready to be commissioned.**

General Cleaning

Bristan products are made from premium materials, with hand polishing and electroplated finishes.

Your taps or shower should be regularly cleaned with warm water, a mild pH-neutral liquid soap, and polished with a soft cloth. Any residues from soap, toothpaste, shampoos and shower gels can cause blemishes if not rinsed off straight after use.

Household bleaches and cleaners contain harsh chemicals and may damage the surface finish. Avoid using abrasive cloths, scouring pads, scrub sponges, steel wool or anything similar. Some surfaces such as nickel and pewter may be affected by the dye found in some cloths, so it is also important to avoid hanging cloths on spouts.

Maintenance - Temperature Adjustment

1

Turn the tap on fully to maximum flow and temperature; let the temperature stabilise.

2

Remove the handle and temperature stop using a screwdriver

3

Turn the cartridge spindle clockwise to decrease the temperature. Turn the cartridge spindle anti-clockwise to increase the temperature.

4

Reverse these steps.

IMPORTANT
This tap is pre-set to 38°C with a maximum temperature override of 45°C.

Please refer to the TMV Type 2 manual for guidance to ensure the tap is kept to TMV Type 2 standards.

The British Burns Association recommends 37 to 37.5°C as a comfortable bathing temperature for children. In premises covered by the Care Standards Act 2000, the maximum mixed water outlet temperature is 43°C.

Maintenance - Clean/Replace Outlet

1

Undo the outlet housing to remove the flow straightener.

2

Place the components in a suitable solution and soak until fully de-scaled.

3

Reverse the steps to replace the outlet.

Maintenance - Valve/Cartridge Cleaning

1

Prise off the caps. Undo the screws using a screwdriver to remove the handles.

2

Remove the spline adapter and then remove the valve using an adjustable spanner.

3

Remove the temperature stop.

Undo the grub screw underneath the tap body to remove the thermostatic cartridge.

4

Visit www.bristan.com or scan the QR Code and search for your product code to replace the cartridge for your tap.

5

Reverse the steps to replace the valves and handles.

Love Your Chrome

Bristan offers an effective chrome-friendly cleaning kit for use with your taps and showers. Scan the QR Code or search for 'CLEAN KIT01' on www.bristan.com.

Troubleshooting

Symptom	Cause	Remedy
No flow or low flow rate	Partially closed isolation valve.	Open isolation valve.
	Instantaneous water heater cycles on and off as flow rate or pressure is too low.	Increase water flow rate or pressure through system.
	Head of water is below the minimum distance required.	Refer to specification for minimum distance required.
	Hot or cold water being drawn off elsewhere causing pressure changes or instantaneous boiler temperature changes.	Do not use other water outlets when using the taps.
	Airlock or partial blockage in the supply pipework.	Flush through pipework to ensure removal of debris and any airlocks.
Water dripping from taps	This is normal for a short time after using the taps.	This is caused by residual water tension, the build up of water in the tap body.
	If water continues to drip, possibly due to the ceramic disc valves	Remove valves and clean, refer to 'Maintenance' section before starting any maintenance.
Taps do not turn on	Closed isolation valve.	Open isolation valve.
	Mains water supply turned off.	Turn on mains water supply.

Contact Us

Customer Service: +44330 026 6273
Web: www.bristan.com
Email: enquire@bristan.com

UK: Bristan Group, B78 1SG.
EU: Masco Europe S.à.r.l.
 14 Rue Strachen
 6933 Mensdorf
 Luxembourg

At Bristan, we want to make things as easy as possible for our customers. That's why we offer solid guarantees on all our products, effective from the date of purchase, to give you peace of mind.

To start your free guarantee simply scan the QR code and register your product. Alternatively visit www.bristan.com/register to register your product via a computer. For full guarantee terms and conditions visit www.bristan.com/guarantees.

We Know & We Care