BRISTAN

Artisan Filter Mixer

Fitting Instruction & Contents List



Please keep these instructions for future reference and request of replacement parts

Contents

Thank you for choosing Bristan, the UK's leading taps and showers expert. We have designed this product with your enjoyment in mind. To ensure that it works to its full potential, it needs to be fitted correctly. These fitting instructions have been created to give you all of the information you need and, if you need any further help, please do not hesitate to give us a call on 0330 026 6273.

Important Safety Information	03
General Specifications	03
Operation	04
Installation Requirements	04
Installation	05-09
Maintenance	10
Guarantee	11

Important Safety Information

- Please read these instructions thoroughly and retain for future use.
- All products manufactured and supplied by Bristan are safe provided they are installed, used correctly and receive regular maintenance in accordance with these instructions
- If you are in any doubt about your ability to install this product safely you must employ the services of an experienced qualified plumber.
- Remove all packaging and check the components for damage before starting installation.
- This product must not be modified in any way as this will invalidate the guarantee.
- These fittings need to be installed in accordance with and meet the requirements of the Water Supply (Water Fittings) Regulations 1999 and Scottish Byelaws 2004.

General Specifications

	Min	Max
Operating pressure range (bar)	0.5	5.0
The Filter cartridge requires a minimum of 2.0 bar		
Maximum static pressure – 10.0 bar		

Designed to comply with BS EN 200 for single taps/ combination taps for water systems of type 1 and 2 general technical specifications and to be used within systems designed to BS 6700.

BS 6700 recommends the temperature of stored water should never exceed 65°C. A stored water temperature of 60°C is considered sufficient to meet all nominal requirements and will minimise the build up of lime scale in hard water areas.

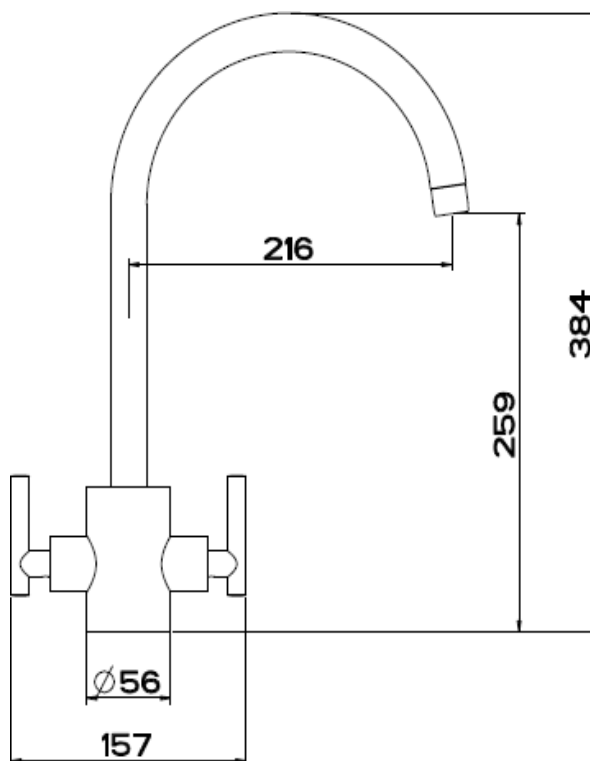

Operation

The mixer provides filtered water by turning the cold handle backwards. Regular hot and cold water are obtained from the usual motion of turning the handles forward from the upright position.

FORWARD
(Anticlockwise)
For regular cold
water

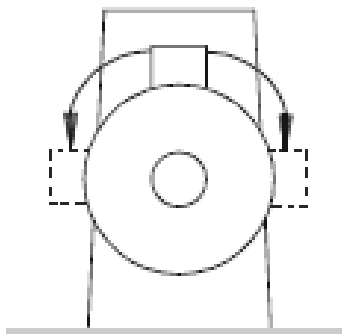

BACKWARDS
(Clockwise)
For filtered cold
water

Installation Requirements

IMPORTANT - PLEASE READ

This/these fitting/fittings needs/need to be installed in accordance with the following Installation Requirements and Notes (IRN) to ensure they meet the requirements of the Water Supply (Water Fittings) Regulations 1999 and the Scottish Byelaws 2004.

IRN R001

See text of entry for Installation Requirements or Notes.

IRN R006

This tap or combination tap assembly has a Type AUK3 air gap and is therefore for installation in any premises to protect against a backflow risk up to a Fluid Category 5.

Installation

Mixer Tap Installation Diagram

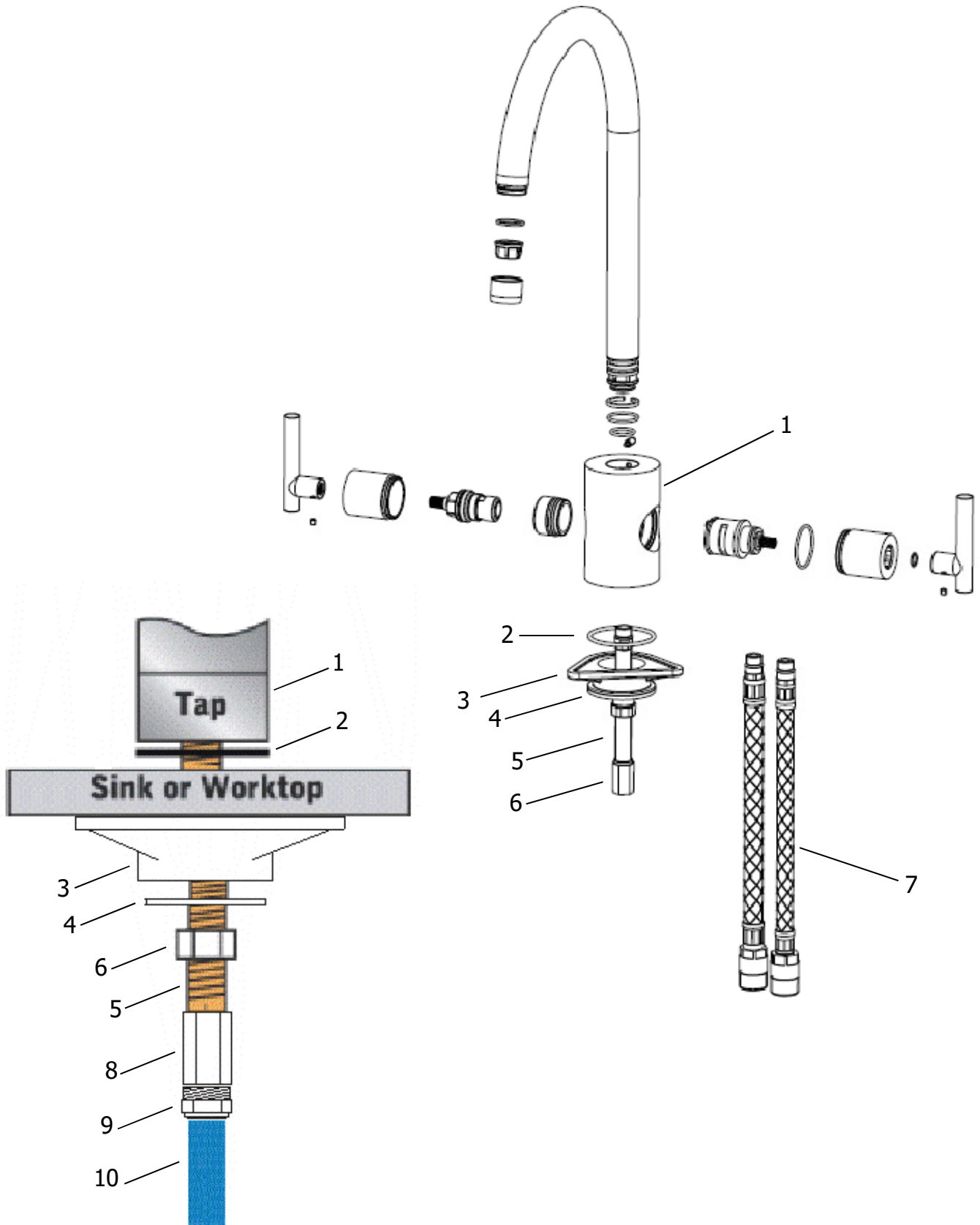

Filter Cartridge

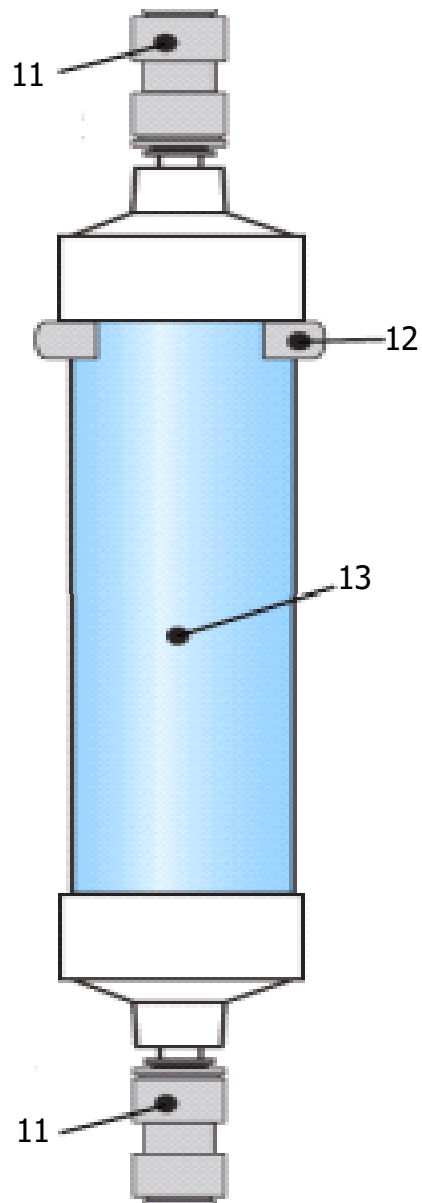

Installation

Important: If the fitting is installed at low pressure (tank fed), then the minimum distance from the underside of the water outlet to the cold water tank should be at least 5 metres to ensure adequate performance.

This mixer should be installed in compliance with Water Regulations. For further details please contact your local Water Authority.

1. Identify all components are present prior to starting installation (see page 5).
2. Install the mixer body (1) to the sink, ensuring the washer (2) is fitted between the mixer body (1) and the sink.
3. Screw the flexible connecting pipes (7) and threaded rod (5) into the bottom of the mixer body (1). See Fig. 1 below.

Important: DO NOT turn on the water supplies until the filter assembly is fully installed.

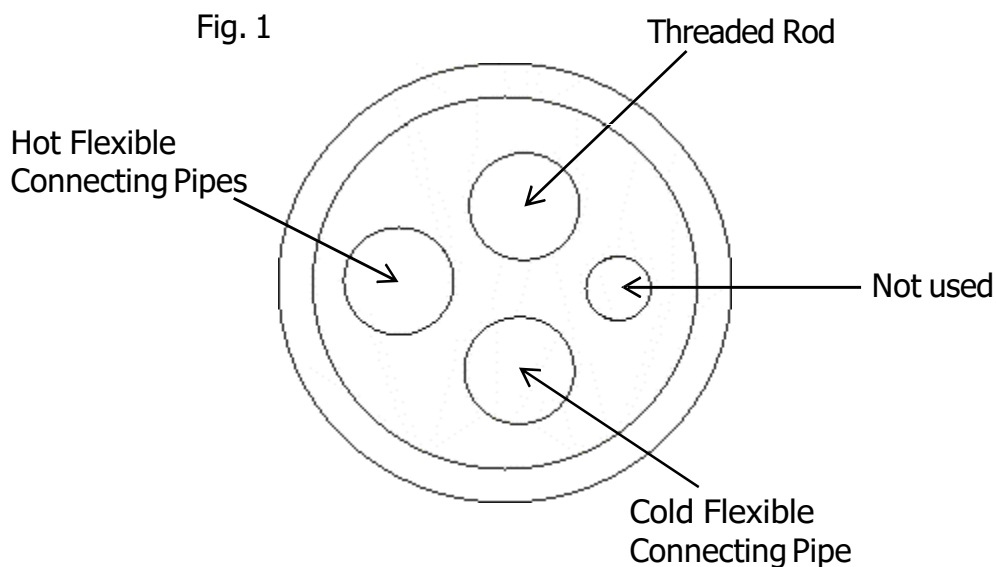

4. Slide the triangular spacer (3) and the 'C' shaped metal washer (4) onto the threaded rod (5) up to the underside of the sink.
5. To secure the mixer in place tighten the fixing nut (6) onto the threaded rod (5) until it is fully tightened against the 'C' shaped metal washer (4).
6. Use the self tapping screws provided to secure the filter bracket (12) to the inside of the sink unit.

Note: The filter cartridge (13) should be mounted vertically and with easy access to ensure future replacement of the filter cartridge is made easy.

- Place the fibre washer supplied into the connecting adaptor (8) and tighten onto the threaded rod (5).
 - Screw the adaptor (9) onto the connecting adaptor (8) and push the blue tubing firmly into the push fit end of the adaptor (9).
 - Push both grey ¼" adaptors (11) firmly onto either end of the filter cartridge (13) as shown in Fig.2.
 - Locate and tighten the self-tapping saddle valve onto the incoming mains supply pipework as shown in Fig.3.
- Important: DO NOT pierce the mains supply pipework until the filter system is fully installed.
- Cut both red and blue tubes to the correct length and firmly push the tubing into the inlet and outlet of the adaptors (11) on each end of the filter cartridge.

Note: The blue tubing fits into the top of the filter cartridge and the red tubing fits into the bottom of the filter cartridge when it is fitted vertically with the arrow on the filter cartridge pointing upwards.

- Pierce the mains water supply pipe by turning the handle of the self-tapping saddle valve fully clockwise until the mains supply pipe has been pierced.
- Turn on both water supplies and operate the mixer handles in both directions letting the water flow for a few minutes to check all joints and connections for any leaks.

Important: Before using the filter system, flush at least 20 litres of water through the tap. The water may at first be greyish in colour which is quite normal, the discolouring is due to excess harmless filter material being rinsed through the filter.

Fig.2

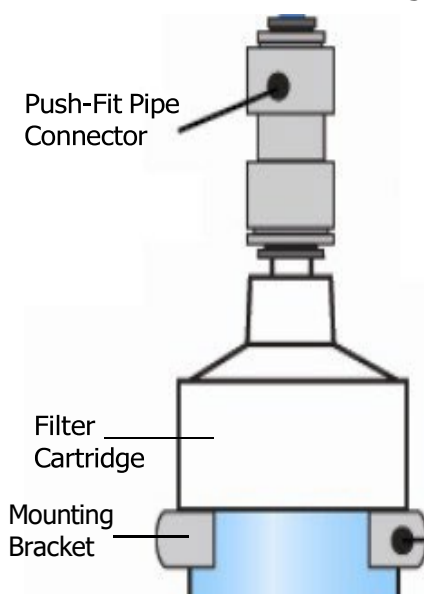
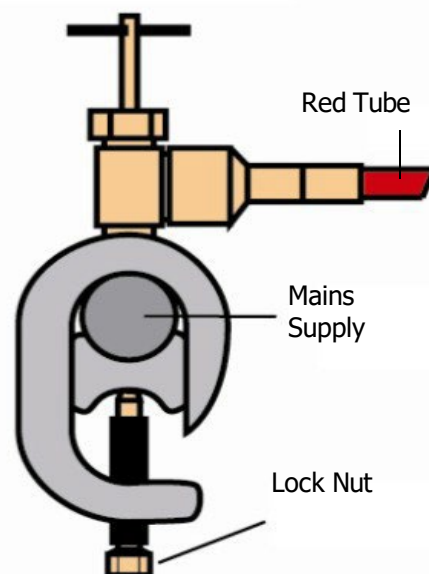
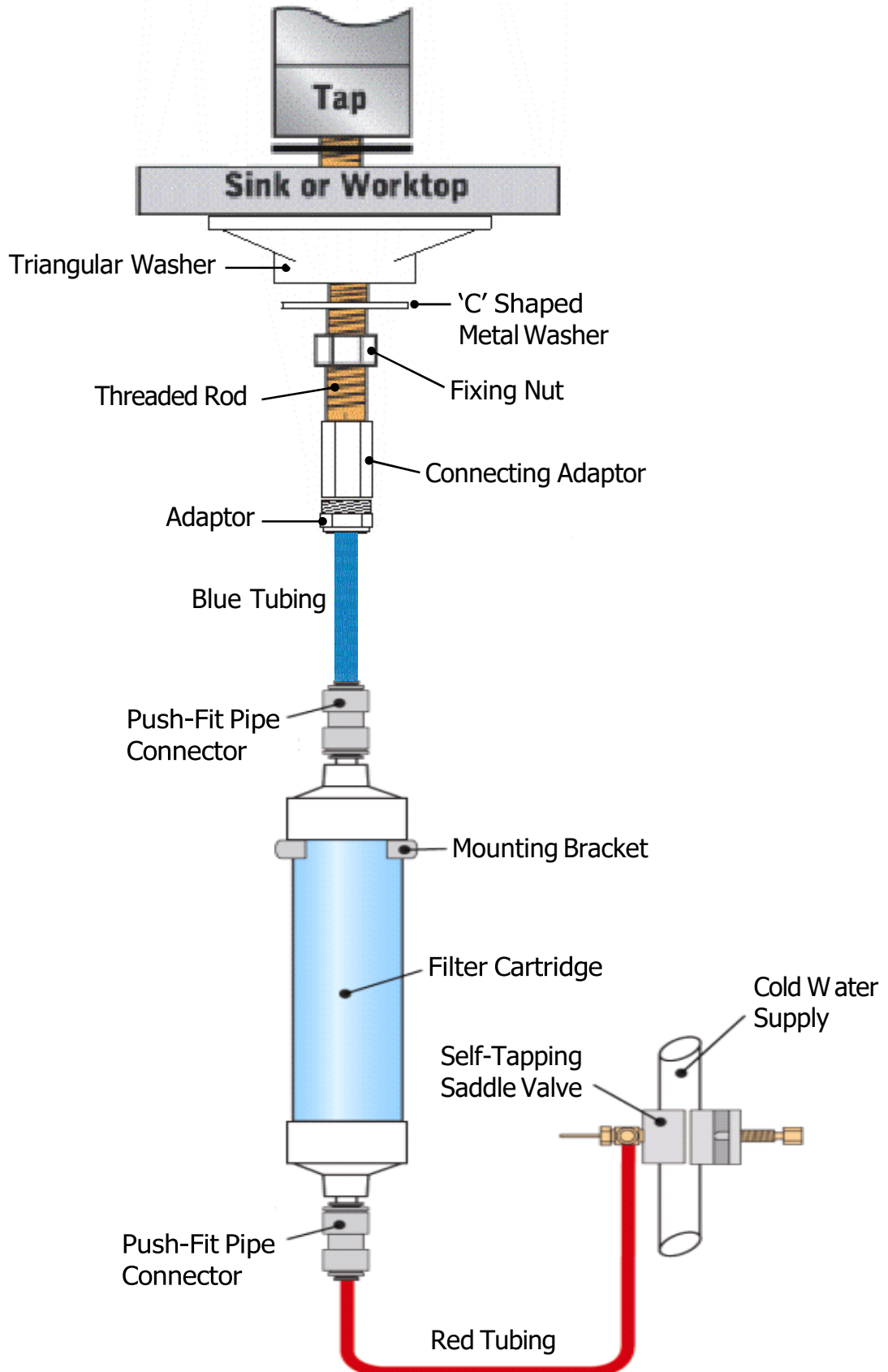

Fig.3

Clockwise to pierce & close



Filter Cartridge Installation Diagram (requires changing every 6 months)



Maintenance

General Cleaning

Your fitting has a high quality finish and should be treated with care to preserve the visible surfaces. All surfaces will wear if not cleaned correctly, the only safe way to clean your mixer tap is to wipe with a soft damp cloth. Stains can be removed using washing up liquid. All bath cleaning powders and liquids will damage the surface of your fitting, even the non – scratch cleaners.

Note: Never use abrasive detergents or disinfectants or those containing alcohol, hydrochloric acid or phosphoric acid.

Maintenance

To maintain correct operation, performance and warranty, please ensure the filter cartridge is replaced every 6 months.

If your tap begins to drip it may be due to the valve letting water pass through and the following should be carried out.

Isolate both hot and cold water supplies to the mixer valve by either:

- Turning the water supply off at the mains stopcock or
- Turning off the isolation valves to the mixer valve.

1. Unscrew the grub screw (1) on the underside of the handle (2).
2. Pull the handle off to reveal the valve (3).

3. Using a suitable box spanner unscrew the handle shroud. Once removed using a suitable spanner unscrew the valve from the mixer body.
4. Carefully clean the valve and the valve seating
5. If necessary replace the valve.
6. Fit the valve back into the tap body and tighten fully using a suitable spanner.
7. Screw the shroud back onto the mixer body using a suitable box spanner. Push the handle (2) onto the spline of the valve and tighten the grub screw (1).

If the problem persists please contact our customer services helpline quoting the product code.

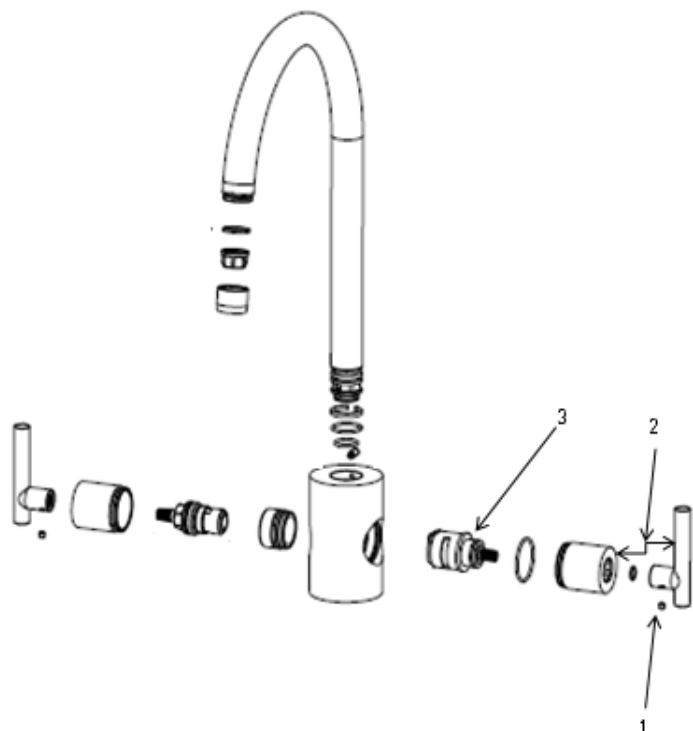

BRISTAN

Bristan Guarantee

At Bristan, we want to make things as easy as possible for our customers. That's why we offer solid guarantees on all our products, effective from the date of purchase, to give you peace of mind.

To start your free guarantee, simply scan the QR code and register your product.

Alternatively, visit www.bristan.com/register to register your product via a computer.

For full guarantee terms and conditions visit, www.bristan.com/guarantees



We Know & We Care

BRISTAN

This booklet covers product code
AR SNKPURE C

Helpline

0330 026 6273

Bristan Group Limited

Birch Coppice Business Park, Dordon, Tamworth, Staffordshire B78 1SG

A Masco Company

Website: www.bristan.com

Telephone: 0330 026 6273

Email: enquire@bristan.com