

# BRISTAN

Quest Basin, Bath & High Neck Taps

Installation Instructions & User Guide



IMPORTANT: Please keep these instructions for future reference and request of replacement parts

---

# BRISTAN

---

## Introduction

Thank you for choosing Bristan, the UK's leading taps and showers expert. We have designed this product with your enjoyment in mind. To ensure that it works to its full potential, it needs to be fitted correctly. These fitting instructions have been created to give you all of the information you need and, if you need any further help, please do not hesitate to give us a call on 0844 701 6273.

## Safety Note

Please read these instruction thoroughly and retain for future use.

All product manufactured and supplied by Bristan are safe provided they are installed correctly, used correctly and receive regular maintenance in accordance with these instructions.

These fittings need to be installed in accordance with and meet the requirements of the Water Supply (Water Fittings) Regulations 1999 and Scottish Byelaws 2004.

## Specification

This product is suitable for use at all supply pressures. If installed at low pressure (tank fed), then the minimum distance from the outlet of the nozzle to the underside of the cold tank should be approximately 2 metres to ensure adequate performance.

	Min.	Max.
Operating pressure range (bar)	0.2	5.0
Maximum static pressure – 10.0 bar		

NOTE:- Nominally equal (balanced) inlet supply pressures are recommended for optimum performance.

## Installation

1. Identify all components and check for completeness, particularly before arranging fitting.
2. Install the taps (1) onto the basin/bath or sink. The backnut (3) and backnut washer (2) are used to secure the tap to the surfaces of basin/bath/sink.
3. Connect the hot and cold water supplies.
4. Turn on both water supplies, open both taps letting the water run for a few minutes to check all joints and connections for leaks.

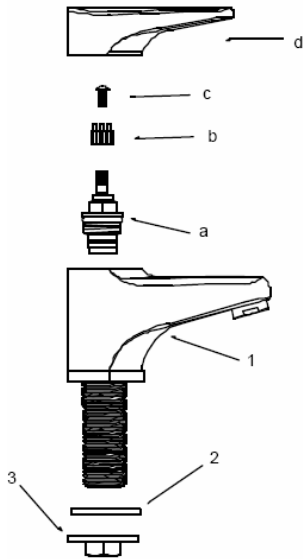

## Contents

1.	Tap Body	x2
2.	Backnut Washer	x2
3.	Backnut	x2
a.	Valve	x2
b.	Spline Adaptor	x2
c.	Screw	x2
d.	Handle	x2

## IMPORTANT - PLEASE READ

These fittings need to be installed in accordance with the following Installation Requirements and Notes (IRN) to ensure they meet the requirements of the Water Supply (Water Fittings) Regulations 1999 and the Scottish Byelaws 2004.

### IRN R001

See text of entry for Installation Requirements or Notes.

### IRN R006

This tap or combination tap assembly has a Type AUK3 air gap and is therefore for installation in any premises to protect against a backflow risk up to a Fluid Category 5.

## Cleaning & Maintenance

Your fitting has a high quality finish and should be treated with care to preserve the visible surfaces.

All finishes will wear if not cleaned correctly. The only safe way to clean your product is to wipe with a soft damp cloth. Stains can be removed using washing up liquid. All bathroom cleaning product (powders and liquids) will damage the surface of your fitting, even the non-scratch cleaners.

NOTE:- Never use abrasive detergents or disinfectants or those containing alcohol, hydrochloric or phosphoric acid.

If the fitting begins to drip:

1. Turn off both water supplies.
2. Remove the handles (d) by pulling from valve (a) and spline adaptor (b). Then remove screw (c), by unscrewing from valve (a)
3. Also remove spline adaptor (b) to avoid damaging it.
4. Using a suitable spanner, remove valve (a). Once removed, carefully clean seating, rubber washer and ceramic disc.
5. Replace all of the above and turn on the water supply.
6. If the problem persists please contact our customer services helpline on 0844 701 6273.

# BRISTAN

This booklet covers product code:

QST ½ C / QST ¾ C / QST HNK C

Helpline  
0330 026 6273

Bristan Group Limited  
Birch Coppice Business Park, Dordon, Tamworth, Staffordshire B78  
1SG

A Masco Company

Website:

[www.bristan.com](http://www.bristan.com)

Telephone: 0330 026 6273

Email: [enquire@bristan.com](mailto:enquire@bristan.com)

At Bristan, we want to make things as easy as possible for our customers. That's why we offer solid guarantees on all our products, effective from the date of purchase, to give you peace of mind.

To start your free guarantee, simply scan the QR code and Register your product.

Alternatively, visit [www.bristan.com/register](http://www.bristan.com/register) to register your product via a computer.

For full guarantee terms and conditions visit, [www.bristan.com/guarantees](http://www.bristan.com/guarantees)



*We Know & We Care*